

## BIOLOGIC CLINICAL DEVELOPMENT USING BIOMICADAS™

### Pharmacokinetics Optimization without Immunoassay Development

Vitalea's technology, The BioMicadas™, a form of Accelerator Mass Spectrometry, addresses the limitations intrinsic to immunoassays. It is ideally suited to solving technical problems unique to Biologic development: Through the addition of a trace  $^{14}\text{C}$  tag using simple chemoselective ligation chemistries, a labeled and *intrinsically active* Biologic may be synthesized and used to obtain quantitative human and animal pharmacokinetic data within months from discovery.

#### Delivers Critical Information

- Optimize human PK rapidly
- Evaluate tissue distribution
- Quantify "payload delivery" to target tissue
- Cross-validate new immunoassay development

#### Delivers Early

- In Phase 0 (30 nmol ceiling limit)
- First in Man studies (IND)
- Before or Concurrent with Most Safety Testing

#### Delivers Efficiently and Cost Effectively

- Faster to Market - months from discovery/modification to human testing
- Absolute and linear quantitation
- Bypass time for immunoassay development
- Femtomolar (pg/mL) sensitivity with superior precision
- Microliter samples sizes required. Can be done with finger-prick assays
- Light  $^{14}\text{C}$  tag can be done with simple, standard chemistries

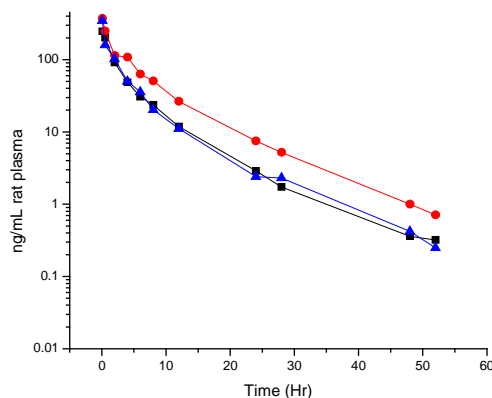

Log transformed pharmacokinetics of a singly  $^{14}\text{C}$ -tagged antibody using a facile  $^{14}\text{C}$ -alkylation reaction.

**MATRIX INDEPENDENCE AND HIGH SENSITIVITY (ATTOMOLE) ALLOWS RAPID EVALUATION OF EVEN THE MOST POTENT BIOLOGICS SAFELY IN HUMANS**

## ABOUT VITALEA

Vitalea Science is a pioneering Bioanalytical Contract Research Organization located in Davis, California. Our services, supported by state-of-the-art Accelerator Mass Spectrometry technologies, the BioMICADAS™, enable the exploration of pharmacokinetics and metabolism of drug candidates directly in humans, both prior to and as part of Phase I clinical trials.

These newly-available approaches can accelerate a candidate or class early in the development process by revealing *true human metabolism, physiochemistry and pharmacokinetics* without reliance on extrapolation from often irrelevant animal models or human cellular assays that lack the full metabolism and target complement of a living person.

Vitalea's *service philosophy* is to develop long-term relationships with our clientele by providing advanced clinical drug development solutions. We uphold this philosophy through a focused emphasis on integrity, teamwork, and exceptional science and technology.

Vitalea has proven *in-house* expertise in bioanalytical assay development, protein and drug labeling, and *in vivo* pharmacokinetics.

On site we have:

- Independent Quality Assurance Unit - GLP compliant
- Board Certified Health Physicist
- Technically Strong Team of Scientists
- Next Generation Technology

The Vitalea Network includes qualified Phase 0/I clinics around the world, radiolabeling laboratories, formulation laboratories and complementary bioanalytical labs to meet all your early clinical needs.

For measurements, study design or dosimetry consultation, contact us at:

1-888-VITALEA, or  
contact@vitaleascience.com

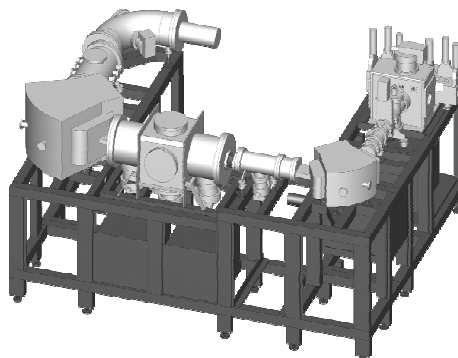

The BioMICADAS™ - The next generation of Accelerator Mass Spectrometry purpose-built for Pharmaceutical Science

